

DC Circuits Practice Items

The diagram below pertains to questions 1-6.

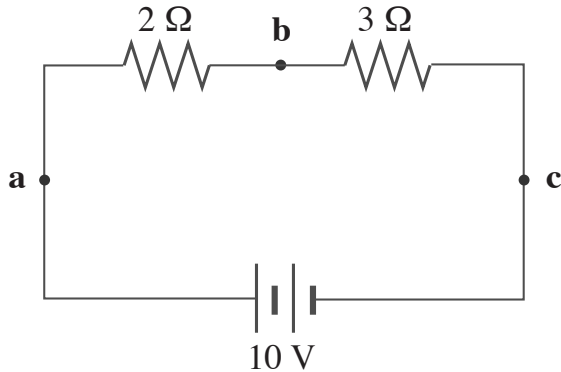

- In what manner does current flow through the circuit?
 - clockwise
 - counter-clockwise
 - there is no current
 - alternating current
- What is the value of the current at point **a**?
 - 0 A
 - 2.0 A
 - 5.0 A
 - 8.3 A
- What is the value of the current at point **b**?
 - 0 A
 - 2.0 A
 - 5.0 A
 - 8.3 A
- What is the potential difference between points **b** and **c**?
 - 6 V
 - 2 V
 - 6 V
 - 10 V
- What is the potential difference between points **c** and **a**?
 - 10 V
 - 2 V
 - 2 V
 - 10 V
- If the two resistors in the circuit are heating elements submerged in 0.5 liters of water, approximately how long would it take to raise the temperature 1 °C?
 - 25 seconds
 - 0.5 seconds
 - almost two minutes
 - about two hours

The diagram below pertains to questions 7 - 12.

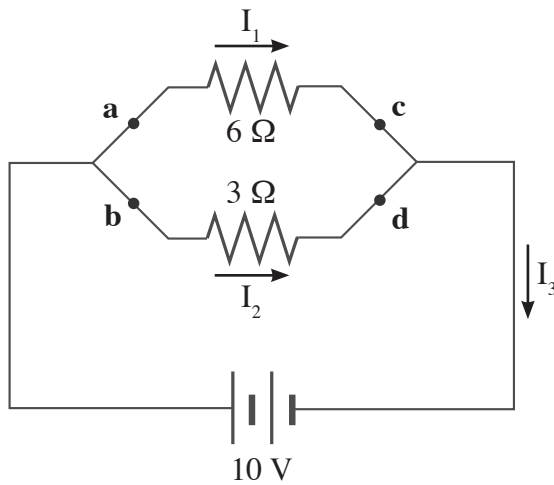

7. In the circuit pictured above, what is the potential difference between points **b** and **c**?

- A. -10 V
- B. -3.3 V
- C. 3.3 V
- D. 10 V

8. What is the value of I_3 ?

- A. 1.1 A
- B. 3.3 A
- C. 5 A
- D. 20 A

9. What is the value of I_2 ?

- A. 1.1 A
- B. 3.3 A
- C. 5 A
- D. 20 A

10. What is the value of the power consumption of the entire circuit?

- A. 2.0 W
- B. 10 W
- C. 20 W
- D. 50 W

11. Assuming the power supply remained unchanged in delivering 10V to the external circuit, if the wire were cut at point **b**, which of the following would occur?

- A. I_1 would increase
- B. I_1 would decrease
- C. I_2 would increase
- D. I_3 would decrease

12. Which of the following statements is **untrue**?

- A. I_2 is twice the value of I_1
- B. $I_1 + I_2 = I_3$
- C. The power consumption of the $6\ \Omega$ resistor is equal to the power consumption of the $3\ \Omega$ resistor.
- D. all are true

The diagram below pertains to questions 13 - 15.

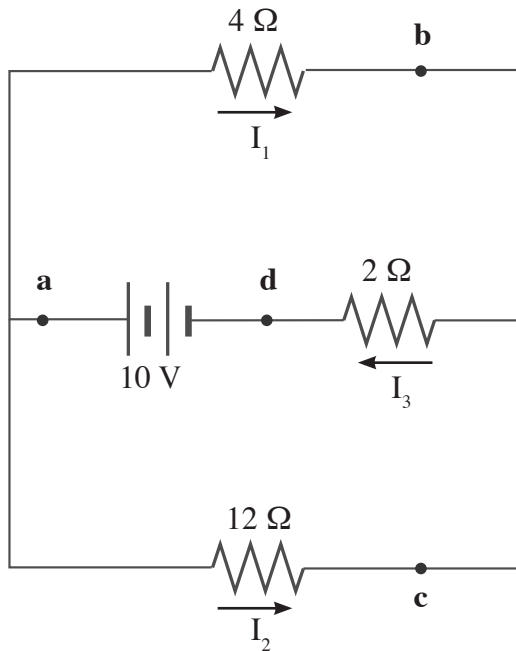

13. What is the value of I_3 ?
- 0.63 A
 - 2.0 A
 - 3.3 A
 - 8.3 A
14. What is the value of the power consumed by the 12Ω resistor?
- 6 W
 - 3 W
 - 72 W
 - $25/3$ W
15. Which of the following statements is **untrue**?
- The potential difference between points b and c is zero.
 - I_1 is greater than I_2 .
 - The potential difference between points b and d is 10 V.
 - All are true.

The diagram below pertains to questions 16 - 17.

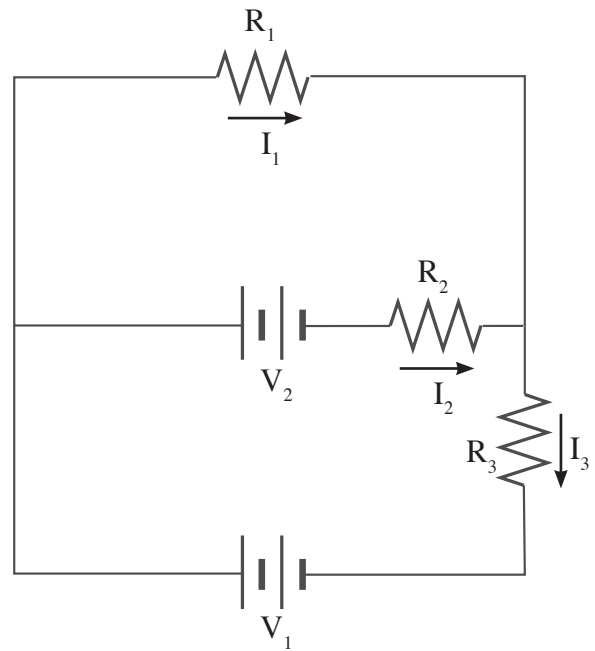

16. Which of the following expressions is incorrect?
- $V_1 - I_1 R_1 - I_3 R_3 = 0$
 - $V_1 - V_2 - I_2 R_2 - I_3 R_3 = 0$
 - $I_1 + I_2 = I_3$
 - all are correct
17. If instead of the voltage source, V_2 , a fully charged capacitor were present at that same position in the circuit, which of the following would occur?
- I_1 would equal I_3 .
 - The rest of the circuit would attain a net positive charge.
 - I_1 would be greater than I_3 .
 - The voltage drop across the capacitor would be equal and opposite to V_1 .

The diagram below pertains to questions 18 - 20.

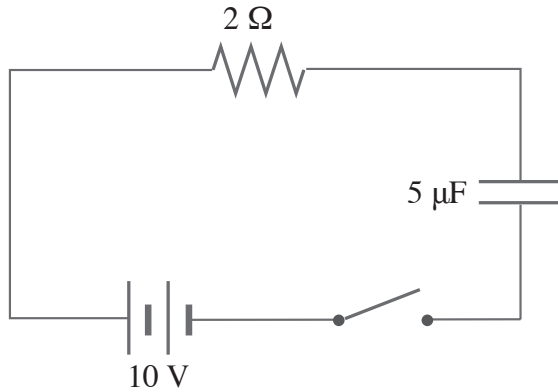

18. In the RC circuit above, what is the maximum rate of power consumption by the resistor?
- A. 5 W
 - B. 25 W
 - C. 50 W
 - D. 100 W
19. When the capacitor has been fully charged, how much charge will it hold?
- A. $50 \mu\text{C}$
 - B. 50 mC
 - C. 2.0 C
 - D. $2.0 \times 10^6 \text{ C}$
20. Which of the following statements predicts the behavior of the circuit?
- A. Immediately after the switch has been closed, the potential drop will be entirely across the resistor.
 - B. After the capacitor has been fully charged, the potential drop will be entirely across the capacitor.
 - C. Employing a dielectric within the capacitor will increase the amount of charge stored in the fully charged capacitor.
 - D. all of the above



© 2020 Wisebridge Learning Systems LLC. Some rights reserved. This work is published under a Creative Commons Attribution Non-Commercial ShareAlike License.

www.integrated-mcat.com



DC Current

Answers and Explanations

1. A

Electrical current is always represented as the net flow of positive charge, even if the charge carriers are electrons such as in a metallic conductor. The current flows from the positive terminal of the voltage source (long bar) to the negative terminal.

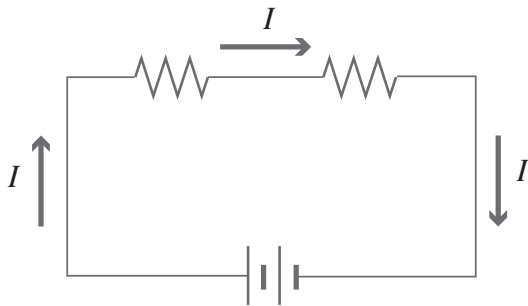

The positive terminal is the zone of positive potential in the circuit. This is where positive charges have high potential energy. It's good to visualize the charges 'falling' through the circuit from the positive to the negative terminal of the voltage source.

2. B

All of the external circuit elements are in series so the current will be the same throughout the circuit. To determine the current first we need to resolve the two series resistors as an equivalent resistance. Because we know the voltage across the two combined, we can then use Ohm's law to determine the current. The equivalent resistance of resistors in series is the sum of the individual resistances. This means that the equivalent resistance is greater than that of any individual resistor.

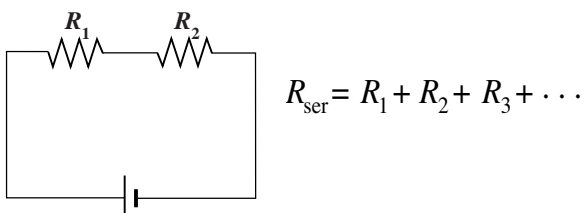

First determine the equivalent resistance.

$$R_{\text{ser}} = 2\Omega + 3\Omega = 5\Omega$$

Now we can compute the current.

$$V = IR$$

$$I = \frac{V}{R}$$

$$I = \frac{10\text{ V}}{5\Omega} = 2.0\text{ A}$$

3. B

All of the external circuit elements are in series so the current will be the same at point **b** as at **a**.

4. A

The potential difference between points **b** and **c** is the change in potential energy per coulomb of charge moved from **b** to **c**. The charges in the current are losing potential energy as they cross the 3Ω resistor so the potential difference between the two points will be a negative value. We refer to this decrease in potential as the voltage drop across the 3Ω resistor.

To determine the voltage drop across the resistor, we just need to use Ohm's law applied to just that resistor.

$$V = IR = (2\text{A})(3\Omega) = 6\text{V}$$

5. D

The potential energy of a charge increases from **c** to **a** across the 10V voltage source so the potential difference is positive 10V.

6. C

First we need to ask how much energy is necessary to raise the temperature of 500g (0.5 L) of water one degree Celsius (1°C)? The specific heat of water is $1\text{ cal/g}^\circ\text{C}$ so we're talking about 500 calories. $1\text{ cal} = 4.18\text{J}$ so this is approximately 2000J. (2092 J to be exact, but the question said we could be approximate, and the answers are widely spaced, so we're safe to make things easier for ourselves).

To find out how long this will take, we need to know the *power* expended in the resistors. Power is the rate

at which energy is supplied to the resistors. Power is the product of the current and the voltage.

$$P = IV$$

2 coulombs per second (2A) of current falling through 10 joules per coulomb (10V) is consuming 20 J/s or 20 W of power.

20W of power requires about 100s to deliver 2000J.

7. A

The voltage drop across parallel circuit elements is the same. The electrostatic force is a conservative force, so the change in potential energy between two points doesn't depend on the path between them. **a** is equipotential to **b** and they are both equipotential to the positive pole of the 10V voltage source. **c** is equipotential to **d** and they are both equipotential to the negative pole of the voltage source. Therefore the potential difference between points **b** and **c** is a 10V voltage drop.

8. C

To determine the primary current in the circuit first we need to resolve the two parallel resistors as an equivalent resistance. Because we know the voltage across the two, we can then use Ohm's law to determine the current. For parallel resistors, the reciprocal of the equivalent resistance equals the sum of the reciprocals of the individual resistances. The equivalent resistance in parallel is less than the resistance of any individual parallel resistor.

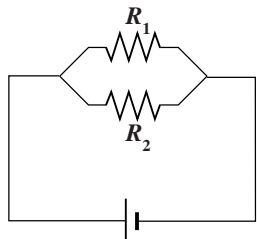

$$\frac{1}{R_{\text{par}}} = \frac{1}{R_1} + \frac{1}{R_2} + \frac{1}{R_3} + \dots$$

First determine the equivalent resistance.

$$\frac{1}{R_{\text{par}}} = \frac{1}{R_1} + \frac{1}{R_2}$$

When there are just two parallel resistors, there is an alternative way to express the formula above that makes the arithmetic a lot easier.

$$R_{\text{par}} = \frac{R_1 R_2}{R_1 + R_2}$$

$$R_{\text{par}} = \frac{(6\Omega)(3\Omega)}{(6\Omega + 3\Omega)} = 2\Omega$$

Now we can compute the current.

$$V = IR$$

$$I = \frac{V}{R}$$

$$I = \frac{10 \text{ V}}{2 \Omega} = 5.0 \text{ A}$$

9. B

I_2 is the branch of the current flowing through the 3Ω resistor. The entire 10V acts across each branch, so we just need to use Ohm's law.

$$V = IR$$

$$I = \frac{V}{R}$$

$$I = \frac{10 \text{ V}}{3 \Omega} = 3.3 \text{ A}$$

10. D

In question 8 we determined the value of the primary current in the circuit, I_3 , to be 5A.

Power is the rate at which energy is supplied to the resistors. Power is the product of the current and the voltage.

$$P = IV:$$

To determine the power,

$$(5 \text{ A})(10 \text{ V}) = 50 \text{ W}$$

11. D

The equivalent resistance in parallel is less than the resistance of any individual parallel resistor. Cutting the wire at point **b** changes the circuit from one with a 2Ω external resistance (the equivalent resistance of the 3Ω and 6Ω parallel arrangement) into one with a single external 6Ω resistor. Increasing the external resistance will decrease the current, I_3 , by Ohm's law.

$$V = IR$$

$$I = \frac{V}{R}$$

12. C

The same 10V is operating across the 3Ω and 6Ω resistors. Current follows the path of least resistance. We can see by Ohm's law that the current is has twice the value through the 3Ω compared to the 6Ω resistor.

$$V = IR$$

$$I = \frac{V}{R}$$

Power is the product of the current and the voltage.

$$P = IV$$

With the same drop in electrical potential across both resistors, the greater current flowing through the 3Ω resistor corresponds to a greater power output. The power consumption is less in the 6Ω resistor.

13. B

In this circuit a set of two parallel resistors (4Ω and 12Ω) are in series with a third resistor (2Ω). The straightforward way to solve this problem is to determine the equivalent resistance of the two parallel resistors first.

$$\frac{1}{R_{\text{par}}} = \frac{1}{R_1} + \frac{1}{R_2}$$

When there are just two parallel resistors, there is an alternative way to express the formula above that makes the arithmetic a lot easier.

$$R_{\text{par}} = \frac{R_1 R_2}{R_1 + R_2}$$

$$R_{\text{par}} = \frac{(12\Omega)(4\Omega)}{(12\Omega + 4\Omega)} = 3\Omega$$

So we can treat the parallel resistor as a single 3Ω resistor in series with the 2Ω resistor. The equivalent resistance of resistors in series is the sum of their individual resistances.

$$R_{\text{ser}} = R_1 + R_2 + R_3 + \dots$$

So the total external resistance is 5Ω . Now we can compute the current, I_3 .

$$V = IR$$

$$I = \frac{V}{R}$$

$$I = \frac{10 \text{ V}}{5 \Omega} = 2.0 \text{ A}$$

14. B

In the previous problem we determined the equivalent resistance of the two parallel resistors (4Ω and 12Ω) to be 3Ω . These two as a set are in series with a third 2Ω resistor, so the total equivalent resistance of the external resistors is 5Ω . With a 10V voltage source, the primary current will be 2A , which we showed in the previous problem.

To determine the voltage drop across the 12Ω resistor, first remember that the voltage drop is the same across both resistors in parallel. As a set they have a 3Ω equivalent resistance. A primary current of 2A is passing through the set. Ohm's law ($V = IR$) tells

us that 6V is required to drive 2A through 3Ω resistance. The voltage drop across the parallel resistors, and thus our 12Ω resistor, is 6V. 6V across a 12Ω resistor will operate at 3W power.

$$P = IV = I^2R = \frac{V^2}{R}$$

$$P = \frac{(6V)^2}{12\Omega} = 3W$$

15. C

Points **b** and **d** are separated by the 2Ω resistor. The entire 10V drop in potential between the positive and negative terminals of the voltage source cannot be occurring all across just that resistor because it is in series with the set of parallel resistors. The voltage falls part of the way as current expends energy in the parallel set of resistors first (4Ω and 12Ω) and then the voltage falls the rest of the way across the 2Ω resistor. We learned earlier that the current through the 2Ω resistor was 2A. Ohm's law ($V = IR$) tells us that 4V is required to drive 2A through 2Ω resistance. In other words, the potential difference between points **b** and **d** is 4V not 10V.

16. D

Statements **A** and **B** are instances demonstrating Kirchoff's second rule: The sum of the changes in potential around any closed path is zero. Statement **C** derives from Kirchoff's first rule: The sum of the currents into a junction equals the sum of currents out of the junction.

17. A

The figure below depicts the circuit with a fully charged capacitor substituted for V_2

With the capacitor fully charged, no current is flowing through the central branch and resistor R_2 . In that case I_1 will equal I_3 .

Regarding choice **B**, if this were a simple RC circuit, the voltage drop across a fully charged capacitor

would be equal opposite to the voltage of the voltage source. In this circuit, however, the voltage drop of the capacitor plus the voltage drop across R_3 will be equal and opposite to the voltage source.

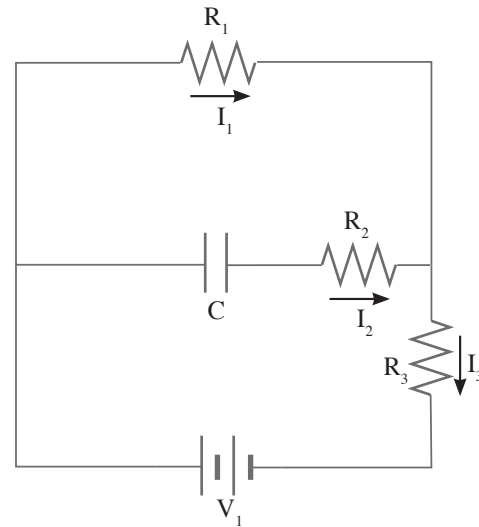

18. C

At the moment the capacitor is just beginning to be charged by the current, after the switch is closed, current will flow through the circuit as if the capacitor were not even there. As charge builds up on its plates, though, its voltage will begin to oppose the charging voltage and the current will begin to slow ultimately down to zero when the capacitor is fully charged and possesses a voltage equal and opposite to the charging voltage.

After the switch is closed, the entire voltage drop will be across the resistor in that moment, so the instantaneous power consumption by the resistor will be:

$$P = IV = I^2R = \frac{V^2}{R}$$

$$P = \frac{(10V)^2}{2\Omega} = 50W$$

19. A

Capacitance reflects the ability of a conductor to store charge. Capacitance is expressed as the relationship between the voltage of the conductor

and the amount of charge stored. Capacitance is measured in farads (F). One farad is equal to one coulomb per volt.

$$C = \frac{Q}{V}$$

The charge stored will equal the product of the voltage across the capacitor and its capacitance.

$$Q = CV$$

$$Q = (5 \mu\text{F})(10\text{V})$$

$$Q = (5 \times 10^{-6} \text{ F})(10\text{V}) = 5 \times 10^{-5} \text{ C}$$

$$= 50 \mu\text{C}$$

20. D

All three statements are correct. When the switch is closed, all of the voltage drop in the circuit is across the resistor, but eventually, as charge builds up on its plates, the voltage drop shifts to the capacitor. When the capacitor is fully charged, current in the circuit will have ceased. However, if a dielectric were between the plates of the capacitor, the capacitor could hold a larger amount of charge before obtaining the same charging voltage.
